

Installation, operating and maintenance manual

Gas pressure regulator GDR Type 132

according to DIN EN 334

Table of content

- 1. General on installation, operating and maintenance manual**
 - 1.1 Hazard notices
 - 1.2 Qualified staff

- 2. Functional description**
 - 2.1 Description
 - 2.2 Sectional drawing/ installation example
 - 2.3 Function

- 3. Installation, operating instructions**
 - 3.1 Installation/assembly
 - 3.2 Pipe connections
 - 3.3 Commissioning

- 4. Inspection and maintenance tasks**
 - 4.1 Inspection/maintenance
 - 4.2 Special maintenance instructions
 - 4.3 Special tools
 - 4.4 Inspection before commissioning / service inspections

- 5. Technical documentation**
 - 5.1 Spare parts drawing
 - 5.2 Spare parts list
 - 5.3 Technical data sheet

- 6. Disposal**

- 7. Inspection certificates/certificates/certifications***
- 8. Documentation of included components**

*Attached here depending on the scope of the order

1. General on installation, operating and maintenance manual

1.1 Hazard notices

These instructions comply with EC safety standards, EC directive 97/23/EC (Pressure Equipment Directive) and the relevant rules and regulations of the Federal Republic of Germany.

When the valve is used outside the Federal Republic of Germany, those responsible for the design and operation of the plant must ensure that the relevant standards and national rules and regulations are observed.

This instruction contains the instructions how to install and operate the valve safely and in the prescribed manner.

If problems arise that cannot be solved with the help these instructions, more information can be obtained from the manufacturer. Non-adherence may cause damage to property, environmental damage and personal injury.

The manufacturer reserves all rights to make technical changes and improvements at any time. The use of these instructions assumes that the user is qualified as described in Section 1.2. The operator has to receive training according to the instructions.

1.2 Qualified staff

Qualified staff are persons who from their training and experience are familiar with the installation, mounting, commissioning, operation and maintenance of the regulator apply. They may carry out inspections, functional checks, maintenance and re-commissioning. At plants regulated by the German Association for Gas and Water (DVGW), a second person must be present.

2. Functional description

The Type 132 gas pressure regulator has the task of keeping the outlet pressure constant, independent of the influence of interference variables such as inlet pressure and/or change in flow rate.

It is used for all gases according to DVGW worksheet G260 and all non-corrosive gases. Special versions are available for corrosive gases, in particular landfill or sewage treatment plant gases.

The Type 132 gas pressure regulator may only be used as intended and exposed to the maximum pressure as indicated on the factory nameplate (see 2.1 Identification).

Design, engineering and manufacturing are carried out on the basis of lifetime-limiting features such as creep rupture strength of pressure-bearing components (AD 2000 1% time yield limit 100,000h). These features limit the permissible period of use.

The Type 132 gas pressure regulator consists of three modules control regulator (I), optional pressure reducer (II) and actuator (III).

As an option, the Type 132 gas pressure regulator can be supplied with primary noise attenuation, an external control nozzle or valve train (see spare parts drawing 4, 5, 6).

If a pressure reducer is installed, the equipment is called a Type 132 m.

The control regulator is available in versions DN and DH; the former is used as standard for the range up to 50 mbar, the latter for the range above 50 mbar operating pressure.

2.1 Identification

The valve is identified with a hard stamp on the valve body and nameplate

Valve body:

Factory number
 Material, possibly according to APZ,
 DN PN, material and standard of the flanged joints

Nameplate

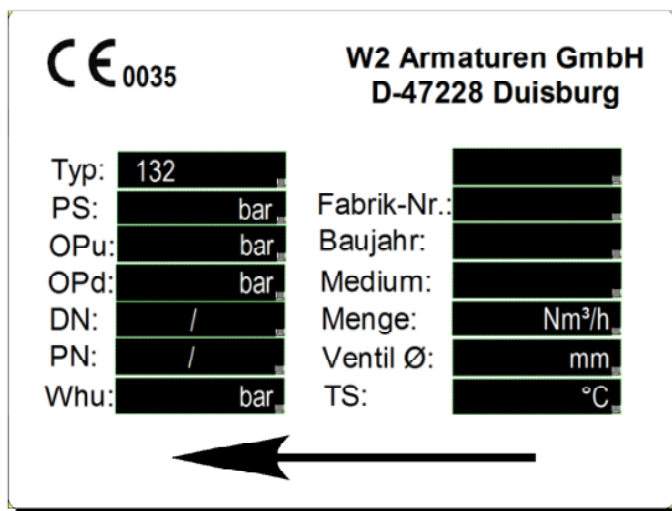

CE according to PED

PS: Pressure Stage
 OPu: Operating Pressure Upstream
 OPd: Operating Pressure Downstream
 DN: Nominal Width
 PN: Rated Pressure
 W_{ds}: Specific Set Input Range (Adjustment Range)

Sectional Drawing/Installation Example
GDR Type 132m

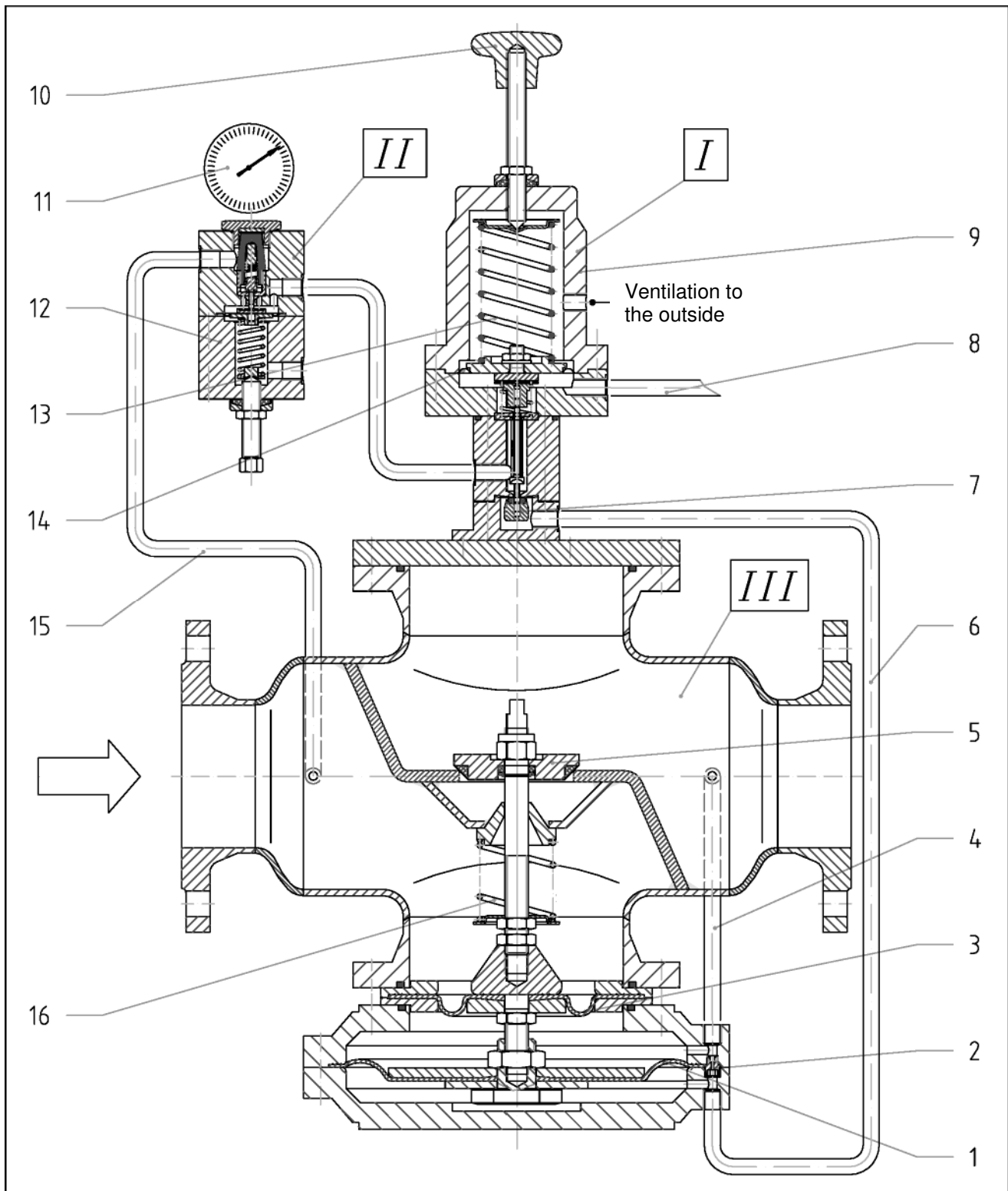

2.3 Function (according to the sectional drawing)

The operating pressure upstream (OPu) flows in front of the cone valve 5 and the compensation diaphragm 3. The cone valve remains closed, also during varying operating pressure upstream.

At a differential pressure between input and output of more than 1.5 bar, a pressure reducing valve 12 is installed in front of the control regulator.

The operating pressure upstream reaches the pressure reducing valve 12 (with integrated filter) via the control pressure line 15. It is set to a favourable control system response and can lie between 0.2 and 1.0 bar above the operating pressure downstream (OPd). The pressure gauge 11 acts as control.

The (possibly reduced) pressure reaches the control regulator 9.

By tensioning the spring 13 with the palm grip turn 10 – turning to the right increases the pressure – the control valve 7 is opened. The control pressure reaches the diaphragm chamber 1 via the loading pressure line 6 and places a load on the working diaphragm 1. The working diaphragm 1 lifts up and opens the cone valve 5. The operating pressure downstream (OPd) that is formed passes through the pulse line 8 under the control regulator diaphragm 14 and lifts it when the set spring value is reached. This closes the control valve 7. The control pressure evens out with the operating pressure downstream via the control nozzle 2 and the outflow line 4, and the cone valve closes again. The gas pressure regulator is in the control position.

3. Installation, operating instructions

3.1 Installation/assembly

The Type 132 gas pressure regulator can be installed horizontally or vertically in the direction of flow. In vertical installations, the control regulator is mounted upright next to the actuator. Due to the special structural design, the measuring pulse can already be installed at a distance of $2-3 \times DN_{\text{output}}$ ($5 \times DN_{\text{output}}$ = better control assembly as indicated) on the outflow zone behind the GDR. To avoid an interruption of the pulse, the maximum flow velocity in the outflow zone should not be higher than 20 m/s.

The breathing or ventilation lines must be safely conducted outdoors.

On-site pressure testing with water is not possible.

Basically DIN EN 12186/EN 12279 has to be adhered to.

3.2 Pipe connections

Ventilation G ¼"

Measuring pulse G ¼"

Pipe couplings G ¼"

3.3 Commissioning

After the regulator has been properly installed and the pulse lines connected, commissioning can proceed as follows (commissioning must comply with the national regulations, accident prevention regulations, the guidelines of the operator and the manufacturer's instructions):

- Close output and input shut-off
 - Release the set point spring of the control regulator
(and possibly of the pressure reducer SR)
 - Slowly open the input shut-off valve; the control pressure may not rise
 - If necessary, adjust the control pressure on the pressure reducer SR
(approx. 0.2 bar to 1.0 bar above set point of the control pressure)

 - Slowly tension the set point spring of the control regulator until the desired pressure is reached

 - Slowly open the output shut-off valve and set exact operating pressure downstream
- The gas pressure regulator is now ready for operation.

To achieve the preset pressure, the spindle must be screwed in after dismantling until it stops. Only then the preset value specified in the enclosed documentation is reached.

4. Inspection and maintenance tasks

4.1 Inspection/maintenance

Special maintenance of the GDR Type 132 is not required. Malfunctions can occur only through dirt or damage to individual components.

For the maintenance of gas pressure-regulating systems, the appropriate provisions, in particular the DVGW worksheets G 491 and G 495 must to be adhered to.

The maintenance intervals depend on the operating conditions and the nature of the gas used. Rigid maintenance intervals are therefore not specified, the responsibility lies with the operator.

All work on the GDR Type 132 or its environment must be carried out in an unpressurised state. The national provisions, the guidelines of the operator and the manufacturer's instructions must be followed.

4.2 SPECIAL maintenance instructions

The actuator *Type 132* (as per spare parts drawing 1) must be checked during maintenance to ensure that the cone valve 13 does not leak; the diaphragms 3, 21 must also be checked for wear and external leakage. To determine the tightness of the cone valve 13, the set point spring of the control regulator must be released and the shut-off valve behind the gas pressure regulator closed. The front shut-off valve must be open. Now the pressure downstream of the gas pressure regulator must not rise any more. To remove the cone valve 13, first loosen the screws 16 and remove the blank flange 17. Now the self-locking nut 14 can be loosened; in so doing it is necessary to hold the valve suspension 9 with the help of the GDR assembly key. Make sure during installation that the items 10, 11, 12, 14 and 15 are also replaced. In order to check the working diaphragm 3, first loosen the screws 23 and remove the lower diaphragm housing 1. The working diaphragm 3 can now be screwed out along with the diaphragm suspension 18 and checked. The position must be maintained during replacement. It is useful to note the turns when unscrewing.

After loosening the screws 24, the upper diaphragm housing 22 can be removed and the compensation diaphragm 21 medium along with the diaphragm suspension 27 and checked; in so doing the centre hex nut 8 must be counter-held using a spanner. When installing, make sure that the items 4, 25 and 26 are also replaced.

The control regulator *Type DH, DN* (as per spare parts drawing 2) must be dismantled from the main unit for maintenance purposes. For this purpose the Ermeto fittings in the input and output must be loosened. Before every disassembling of the control regulator the set point spring 12 must be released with the palm grip 17. During maintenance, the diaphragm 8, the control regulator insert (2, 3, 4) and the control valve 1 in particular must be checked for wear. By loosening the screws 19, the diaphragm 8 can be taken out along with the suspension 7 and checked. By unscrewing the spring cap 6 and loosening the screws 21 and 27, the control valve 1 can be unscrewed from the control regulator insert (2, 3, 4), the insert removed and checked. To maintain the general operational reliability, the insert should be replaced at least every 5 years. When assembling, make sure that the control valve 1 is screwed to about ¼ turn before the stop on the control regulator insert (2, 3, 4). In addition, the spring cap 6 on the control regulator insert (2, 3, 4) must be screwed on only to the extent

that when depressing the spring cap 6, the control valve 1 stands about 2 mm up from the seat of the regulator body 24.

The pressure reducer *Type SR* (as per spare parts drawing 3) with integral sintered metal filter can be removed for maintenance purposes. For this purpose the Ermeto fittings in the input and output must be loosened. The function test can be performed on a test rig when removed. Before every disassembling of the pressure reducer the set point pressure spring 8 must be released with the help of the spindle 11.

During maintenance, specifically the diaphragm 6 must be checked for wear and the filter body 21 for free passage. By loosening the Allen screws 10, the upper valve body 15 can be removed and the diaphragm 6 with diaphragm suspension 5 and diaphragm plate 7 can be removed and checked.

By loosening the screw plug 1, the filter body 21 can be removed together with the valve insert 4. If the filter body no longer shimmers yellow-gold, it must be replaced. To maintain the general operational reliability, the filter body should be replaced at least every 2 years.

4.3 Special tools

GDR installation key, available from R+A Terschüren GmbH

4.4 Inspection before commissioning / service inspections

The operator must do and document service inspections before commissioning and at regular time intervals. The intervals specified in the DVGW worksheet 495 apply.

Inspections relating to, among other, compliance with the construction requirements, equipment integration, leaks and function with due regard to the DVGW worksheet 491.

5. Technical documentation

5.1 Spare parts drawing

x: Keep wear parts in stock for maintenance.
 The storage requirements of the respective manufacturers apply.

Spare parts drawing 1 **Actuator Type 132**

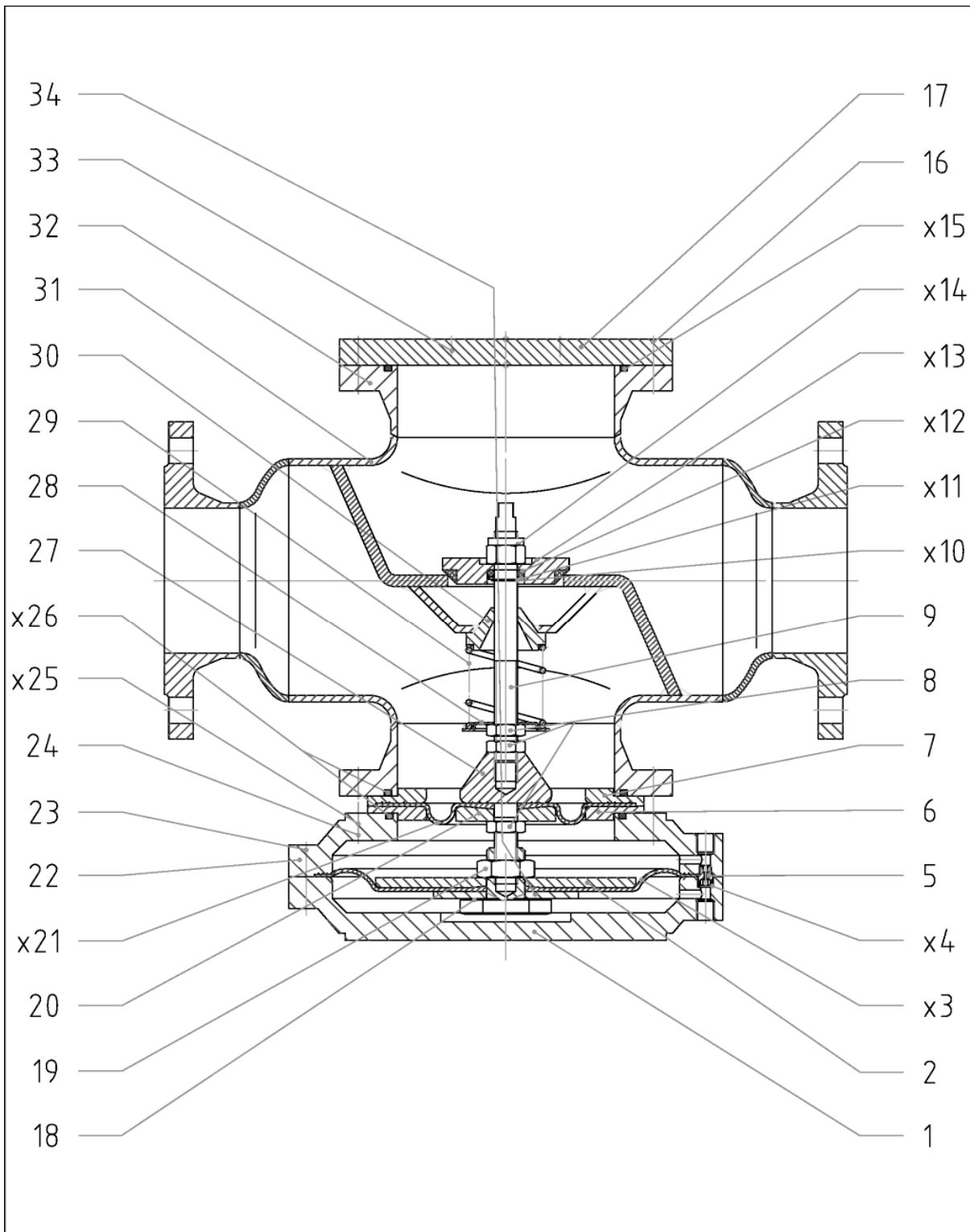

Spare parts drawing 2

Control regulator Type DH, DN

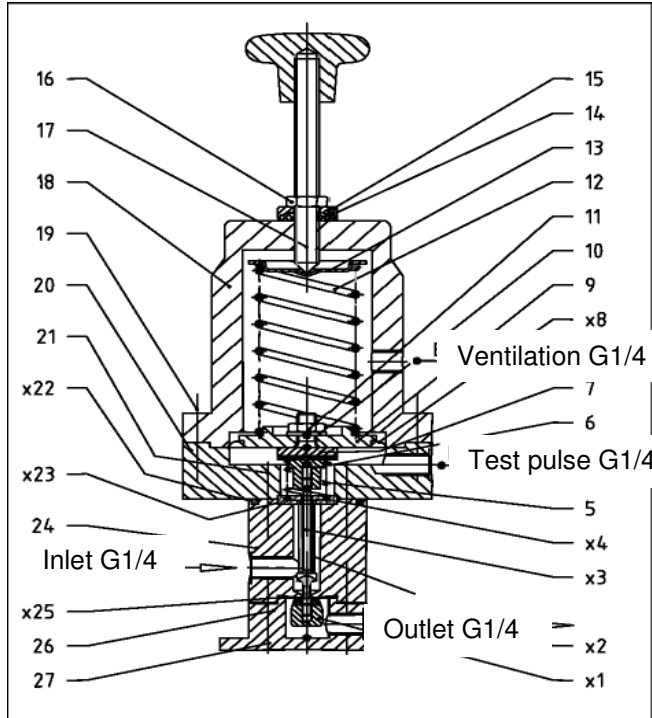

Spare parts drawing 3

Pressure-reducing valve Type SR

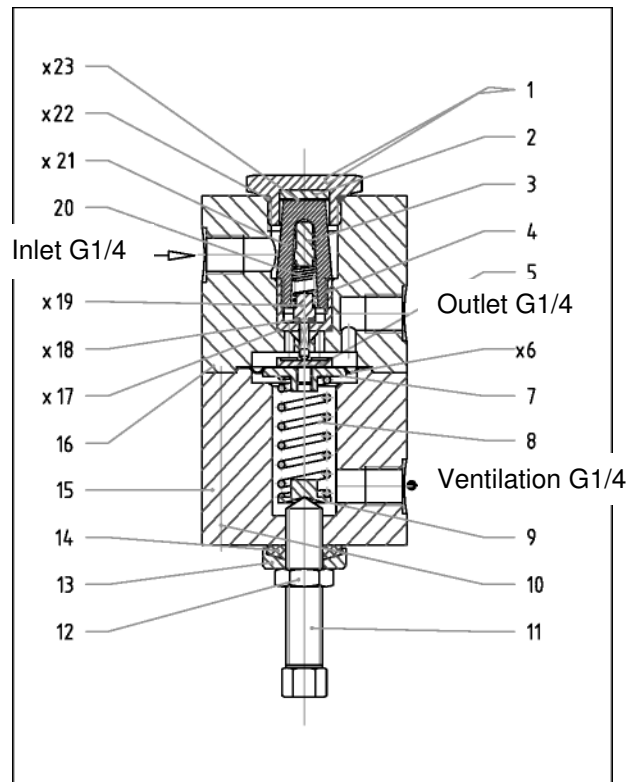

Spare parts drawing 4 **Optional primary noise attenuation**

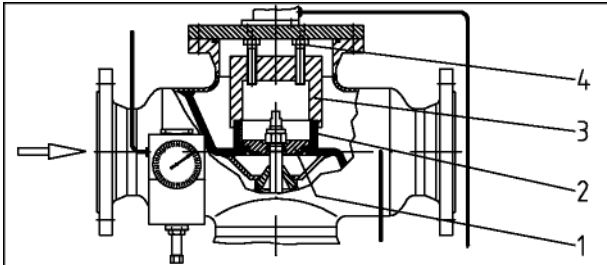

Pressure release noises can be reduced by approximately 10 - 20 dBA with the help of primary noise attenuation. It can be retrofitted at any time. It is important to ensure that the noise attenuation **2** is placed concentrically with holder **3** over the valve **1**. With the rubber seal the screws **4** should stand about 2-3 mm over the edge of the body flange so that enough pressure is created.

Spare parts drawing 5 **Optional external control nozzle**

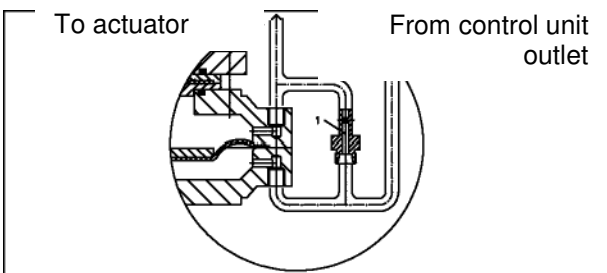

The external control nozzle is used when:

- Soiling and blockage are expected
- Steel membrane housing is used
- Easier and quicker access to the control nozzle is required

The control nozzle is designed standard with an Ermeto 10L coupling.

Spare parts drawing 6 **Optional motor control**

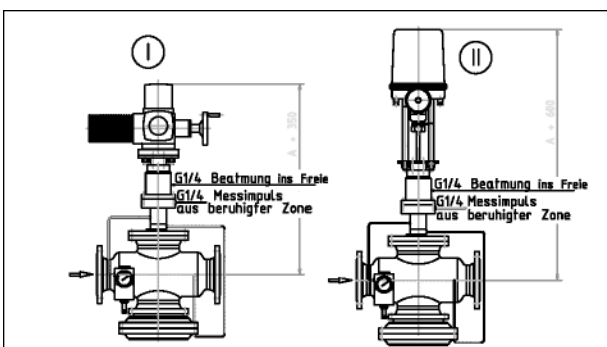

Instead of a hand wheel, gas pressure regulators can be fitted with a fix-mounted motor for electric adjustment.

It is available as rotary and linear actuator.

5.2 Spare parts list

Spare parts list 1 **Actuator Type 132**

Item	Quantit	Unit	Designation	Standard / drawing number	Material / remarks
1	1	Piece	Diaphragm housing, bottom	4-132-1/...	GGG 40 / St
2	1	Piece	Diaphragm plate, working	4-132-2/...	St, chromated
x3	1	Piece	Working diaphragm	4-132-3/...	Perbunan
x4	1	Piece	Control nozzle seal	8 x 12 x 6	Perbunan
5	1	Piece	Control nozzle	4-132-5	VA
6	1	Piece	Diaphragm ring, bottom	4-132-6/...	St, chromated
7	1	Piece	Diaphragm ring, top	4-132-7/...	St, chromated
x8	3	Piece	Hexagon nut	DIN 439, M16	St, galvanised
9	1	Piece	Valve suspension	4-132-9/...	VA
x10	1	Piece	Seeger ring	DIN 471, 16 x 1	Spring steel, galvanised
x11	2	Piece	Sealing ring	DIN 7603 A, 16 x 24 x 1.5	Cu
x12	1	Piece	O-ring	16 x 5	Perbunan/Viton
x13	1	Piece	Cone valve	4-132-13/...	Al, Perbunan
x14	1	Piece	Locknut	DIN 982, M16	St, galvanised
x15	1	Piece	O-ring	158x5/ 168x5	Perbunan
16	8/12	Piece	Allen screw	DIN 912, M12 x 20 / 30	8.8, galvanised
17	1	Piece	Blank flange	4-132-17/...	St, chromated
18	1	Piece	Working diaphragm	4-132-18/...	Al
19	1	Piece	Hexagon nut	DIN 431, G3/4	St, galvanised
20	1	Piece	Diaphragm plate	4-132-20	Al
x21	1	Piece	Compensation diaphragm	4-132-21/...	Perbunan/Viton
22	1	Piece	Diaphragm housing, top	4-132-22/...	GGG 40 / St
23	16	Piece	Allen screw	DIN 912, M10 x 30	8.8, galvanised
24	8	Piece	Allen screw	DIN 912, M12 x 45	8.8, galvanised
x25	8	Piece	Sealing ring	DIN 7603, 12 x 18 x 1.5	Cu
x26	2	Piece	O-ring	~ 5	Perbunan
27	1	Piece	Compensation diaphragm	4-132-27	Al
28	1	Piece	Spring cup	4-132-28	St, chromated
29	1	Piece	Closing spring	4-132-29	Spring steel C, chromates
30	1	Piece	Valve guide	4-132-30	St
31	1	Piece	Body	4-132-31/...	St
32	2	Piece	Body flange	4-132-32/...	St
33	2	Piece	Allen screw	DIN 912, M8 X 15	8.8, galvanised
34	1	Piece	Diaphragm disc	4-132-34	St, chromated

Spare parts list 2

Control regulator Type DH, DN

Item	Quantit	Unit	Designation	Standard / drawing number	Material / remarks
x1	1	Piece	Control valve	4-St-1/D	VA
x2	1	Piece	Spring body	4-St-2	MS / VA
x3	1	Piece	Valve suspension	4-St-3/D	VA
x4	1	Piece	Solder flange	4-St-4	VA
5	1	Piece	Closing spring	4-St-5	VA spring steel
6	1	Piece	Spring cap	4-St-6	VA
7	1	Piece	Diaphragm suspension	4-St-7	VA
x8	1	Piece	Diaphragm	4-St-8/...	Perbunan
9	1	Piece	Diaphragm plate	4-St-9/...	Al
10	1	Piece	Disc	DIN 125; 10.5x2.5; Form B	St, galvanised
11	1	Piece	Hexagon nut	DIN 439; M10;	St, galvanised
12	1	Piece	Set point spring	4-St-12/...	Spring steel C, chromated
13	1	Piece	Spring cup	4-St-13	St, chromated
14	1	Piece	Stem seal	4-St-14	Perbunan
15	1	Piece	Press ring	4-St-15	VA
16	1	Piece	Hexagon nut	DIN 431; G1/4;	St, galvanised
17	1	Piece	Palm grip with spindle	4-St-17	Ms; Duroplast
18	1	Piece	Diaphragm housing, top	4-St-18/...	Al
19	8	Piece	Allen screw	DIN 912; M6x20;	8.8, galvanised
20	1	Piece	Diaphragm housing, bottom	4-St-20/...	Al
21	4	Piece	Allen screw	DIN 912; M6x25;	8.8, galvanised
x22	1	Piece	O-ring	48 x 4	Perbunan
x23	1	Piece	O-ring	26 x 2	Perbunan
24	1	Piece	Regulator body	4-St-24/D	Al
x25	1	Piece	O-ring	26 x 2	Perbunan
26	1	Piece	Regulator base	4-St-26/D	Al
27	4	Piece	Allen screw	DIN 912; M6x35; 8.8	8.8, galvanised

Spare parts list 3

Pressure reducer Type SR

Item	Quantit	Unit	Designation	Standard / drawing number	Material / remarks
1	1	Piece	Screw plug	4-SR-1	VA
2	1	Piece	Shim	18.5 x 6	Foam rubber
3	1	Piece	Spring pressure piece	4-SR-3	VA
4	1	Piece	Valve insert	4-SR-4	Ms
5	1	Piece	Diaphragm suspension	4-SR-5	St, chromated
x6	1	Piece	Diaphragm	4-SR-6	Perbunan
7	1	Piece	Diaphragm plate	4-SR-7	Al
8	1	Piece	Set pressure spring	4-SR-8/...	Spring steel C, chromates
9	1	Piece	Spring cup	4-SR-9/...	St, chromated
10	4	Piece	Allen screw	DIN 912; M6 x 65	8.8, galvanised
11	1	Piece	Spindle	4-SR-1 1	Ms
12	1	Piece	Hexagon nut	DIN 431; G1/4	St, galvanised
13	1	Piece	Press ring	4-St-15	Ms
14	1	Piece	Stem seal	4-St-14	Perbunan
15	1	Piece	Valve body, top	4-SR-15	Al
16	1	Piece	Valve body, bottom	4-SR-16	Al
x17	1	Piece	O-ring	17 x 1.5	Perbunan
x18	1	Piece	O-ring	2.9 x 1.78	Perbunan
x19	1	Piece	Control valve	4-SR-19	Ms
20	1	Piece	Closing spring	4-SR-20	VA spring steel
x21	1	Piece	Filter body	4-SR-21	Sintered bronze
x22	1	Piece	O-ring	22 x 3	Perbunan
x23	1	Piece	Sealing washer	18.5 x 0.4	PTFE

6. Disposal

Environmental damage can occur during disposal when the equipment still contain poisonous fluid residues.

It is therefore essential to ensure that the equipment is cleaned and free of fluid residues before disposal.

After that, all materials can be disposed of according to the regulations applicable at the operating site.